

# VISION LITES - SLIMLINE - VSIG INSTALLATION & MAINTENANCE GUIDE | 14I-323

## GENERAL:

Low profile Slimline™ vision lite mounts flush to the door providing a clean, aesthetic look. VSIG is designed to fit 1" to 3" doors and accommodates glazing thicknesses of 3/16" to 1-11/16".

## TOOLS NEEDED:

- Phillips - Standard; Torx as option

## INSTALLATION:

1. Read and follow the installation requirements of the door manufacturer.
2. Cut the hole in the door to correspond to the order size of the vision frame. Assure that the opening is plumb and square.
3. Prepare the cutout if required, per the door manufacturer's installation instructions.
4. Carefully inspect the glass edges. Superficial chips smaller than 5/32" (4mm) are acceptable, however, deeper chips (with V profile) are not acceptable and should not be installed.
5. Install glazing tape or frame and/or glass per instructions below.
  - a.) UL 10B, UL10C - apply 1/16" glazing tape (or other required) to glass on both sides. FIG 1.
  - b.) UL10C Exception for 20-Minute Wood Doors: Use 1/8" thick glazing tape. Intumescent glazing tape is not required.
    - i.) Only for 3/16" Keralite and 1/4" wire glazing in cold rolled steel or galvaneal frame.
    - ii.) Screws tightened to a torque setting of 25 inch-pounds.
6. Insert the corridor side frame in the cutout, squaring to door.
7. Insert glass into frame, seating firmly, using setting blocks as needed. Install so that the appropriate markings on the glass remain permanently visible.
8. Inserting two of the screws provided in the countersunk holes, carefully align the room side of the frame to the holes in the corridor side of the frame. Screw in enough to hold frame in place for alignment, then insert the other screws lightly. Tighten the screws to 15-25 inch-pounds alternately in a criss-cross pattern to avoid putting more pressure on one side than the other. Do not tighten to the point of deflecting the frame.

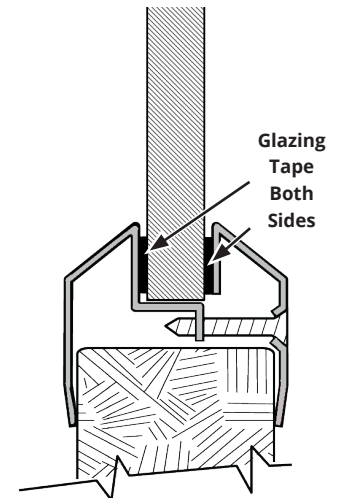

FIG. 1

## MAINTENANCE:

Periodically clean the frame of dust and debris with a dry cloth.



**AIR LOUVERS**

9702 Newton Ave S. Bloomington, MN 55431 | Many Locations Nationwide

800-554-6077

sales@activarcp.com

www.activarcp.com

**VSIG**  
**Installation & Maintenance Guide**

**14I-323**

REV A 5-20-2024