

ROOF ACCESSORIES - DIAMOND SERIES SAF-T-HATCH™

The Diamond Series Saf-T-Hatch is a complete roof hatch with bolt-on safety railing. It is an all-in-one solution to ensure compatibility between the roof hatch and safety railing, that complies with OSHA fall protection requirements..

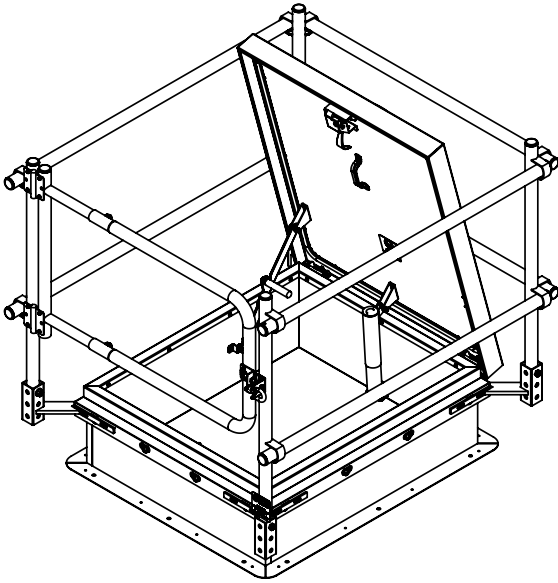

SAF-T HATCH™ WITH GATE EXIT ON LENGTH
Typical for Ladder Access Hatches

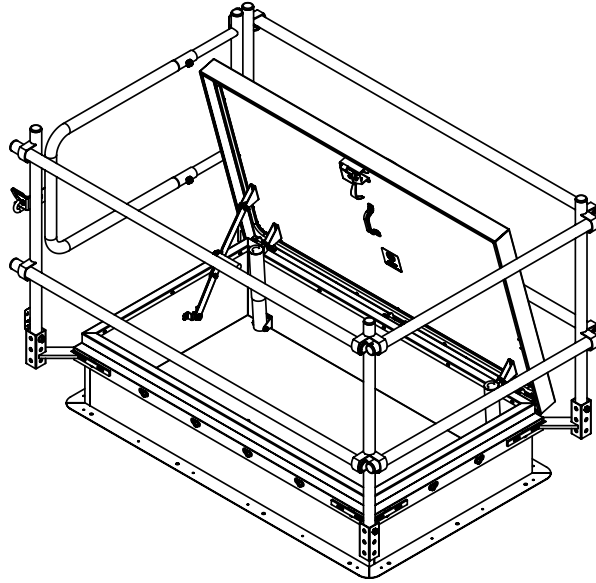

SAF-T HATCH™ WITH GATE EXIT ON WIDTH
Typical for Stair Access Hatches

SPECIFICATIONS:

RHDG - STEEL DIAMOND SERIES ROOF HATCH

Material: 14 gauge galvalume steel curb and cover with 22 gauge galvalume steel liner

Finish: White textured powder coat

Hinge: Heavy duty clear zinc-plated steel pintle hinge

Latch: Clear zinc-plated steel slam latch with inside and outside handles and padlock hasps. Tested to 50psf wind uplift

Gasket: Continuous, weatherproof EPDM sponge rubber adhesive-backed seal

Spring: Counterbalanced compression springs contained in clear zinc-plated steel cylinders

Hold Open Arm: Clear zinc-plated steel hold-open arm

Insulation: 1" polyisocyanurate (R-6) on curb and in cover

RSHWB BOLT-ON RAILING

Material: 1-5/8" x .065" (16 gauge) galvanized steel tubing

Bracket Material: 2" x 2" x .120" square galvanized steel tubing 1/4" and 1/2" plate cold rolled steel

Finish: Yellow powder coat

Hinges: Steel, adjustable spring hinges

Gate: Self-closing, self-latching with telescoping size adjustment

Latch: Steel, black powder coat pin hooks around gravity latch catch

Hardware: Black plastic tubing caps and zinc plated steel hardware

Performance: 200LBS with max 3" deflection per OSHA 1910.29, ANSI 1264.4, 50 PLF (pounds per linear foot) per 2024 IBC 1607.9 (ASCE 7)

NOTES: Install the corner posts in one of the three vertical bolt holes so the top rail is 42" above the walking surface, as required by OSHA 1910.29(b)(1) and 2024 IBC 1015.3

COMMON SIZES

QTY	MODEL	CURB OPENING W X L	GATE EXIT	APPROX. SHIPPING WEIGHT LBS
	RHDG-1WT-STH	36"x 30"	Length	212
	RHDG-2WT-STH	30"x 54"	Width	269
	RHDG-3WT-STH	30"x 96"	Width	388
	RHDG-4WT-STH	36"x 36"	Length	235
	RHDG-5WT-STH	48"x 48"	Length	317
	RHDG-6WT-STH	32"x 72"	Width	92
	RHDG-7WT-STH	37"x 30"	Length	75



JL INDUSTRIES

9702 Newton Avenue S, Bloomington, MN 55431

800-554-6077

sales@activarcpg.com

www.activarcpg.com

Distributor:

Contractor:

Date:

Scale: N/A

Pages: 1 of 2

Project:

Approved By:

Architect:

Item#:

SAFETY RAILING WITH GATE EXIT ON LENGTH

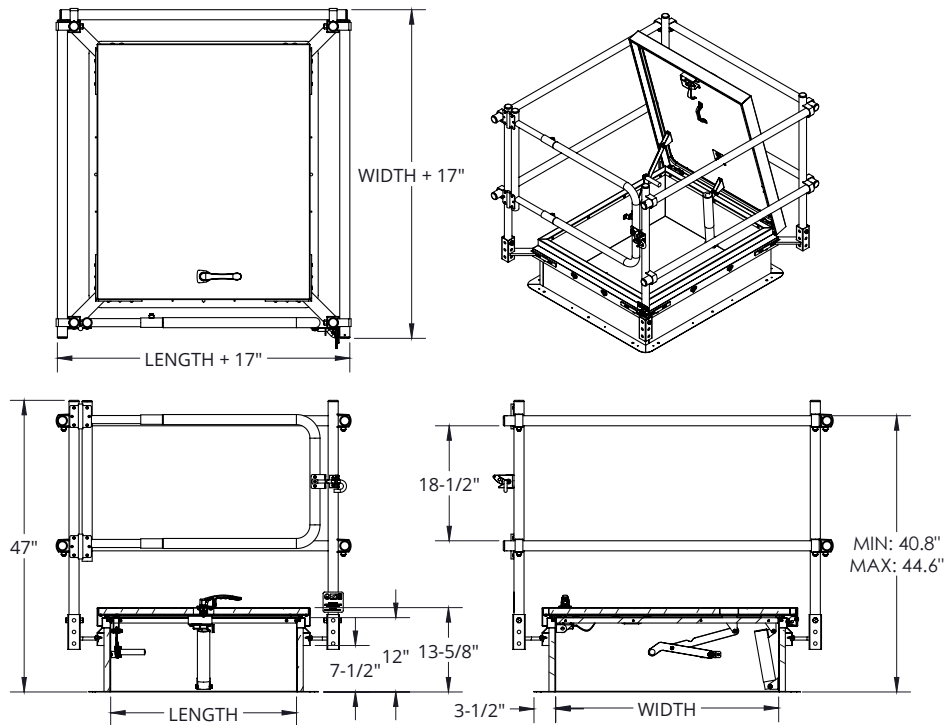

SAFETY RAILING WITH GATE EXIT ON WIDTH

