

**ROOF ACCESSORIES - FARHRENHEIT™ SERIES SMOKE VENT - RVF**

Our UL 793 Listed double door domed smoke vents provide natural daylighting where smoke vents are installed. Smoke vents automatically open during a fire with a heat responsive device, releasing harmful smoke and fumes. Smoke vents are required as referenced in International Building Code section 910 for smoke and heat removal in storage and warehouse occupancies.

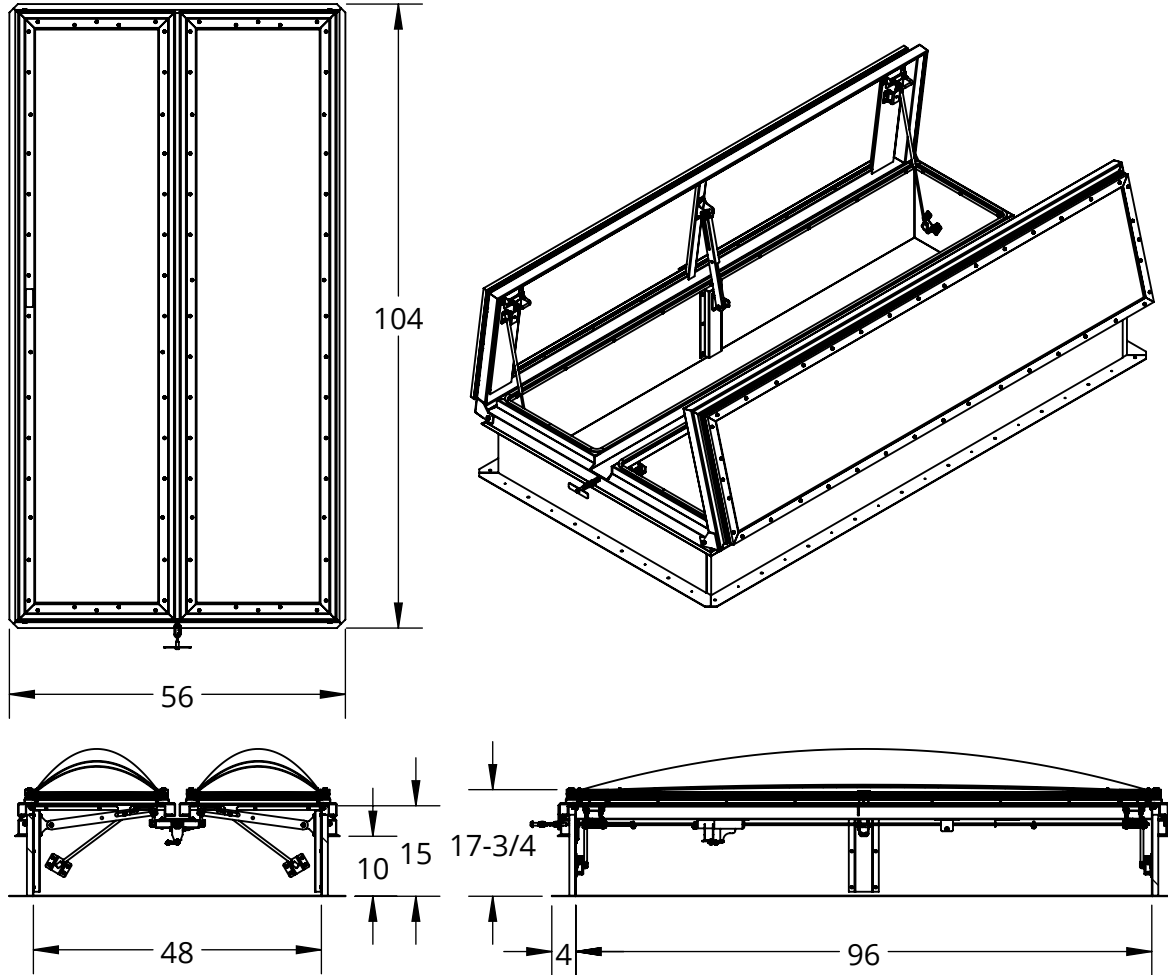

**SPECIFICATIONS:**

**Material:**

**Curb:** 14 gauge galvalume steel

**Cover:** Polycarbonate domes with aluminum extrusion frame

**Finish:** Silver textured powder coat paint

**Dome:** Clear over white polycarbonate

**Gasket:** Bulb neoprene door seal

**Insulation:** 1" polyisocyanurate (R-6) on curb

**Hinge:** Heavy-duty aluminum hinge with bolt pin

**Hold-Open Arm:** Clear zinc-plated steel hold-open arm

**Latch:** Rotary latch mechanism designed to hold covers closed against 90psf wind uplift. Opens manually with internal and external manual pull handles and automatically with fusible link

**Fusible Link:** 165° UL 33 listed fusible link

**Spring:** Gas springs with dampers automatically open against 10PSF snow load

**Size:** 48" x 96"

**ROOF OPENING = ORDER SIZE**

**CERTIFICATIONS:**

UL 793 listed and labeled

**MODEL #:** RVFVGA-4896ST



**DUR-RED PRODUCTS**

9702 Newton Avenue S, Bloomington, MN 55431

800-554-6077

sales@activarcp.com

www.activarcp.com

Distributor:		Project:	
Contractor:		Approved By:	
Date:		Architect:	
Scale: 1:32	Pages: 1 OF 1	Drawing #:	RVFVGA-4896ST-SUBMITTAL