

ROOF ACCESSORIES - SAFETY RAILING, COMPRESSION SERIES - RSHWC

The OSHA compliant, patented compression series safety railing is ideal for existing roof hatches. It's designed to mount on the curb counterflashing with adjustable width and length to accommodate other manufacturer's designs. In addition, the overall height is adjustable to ensure code compliance.

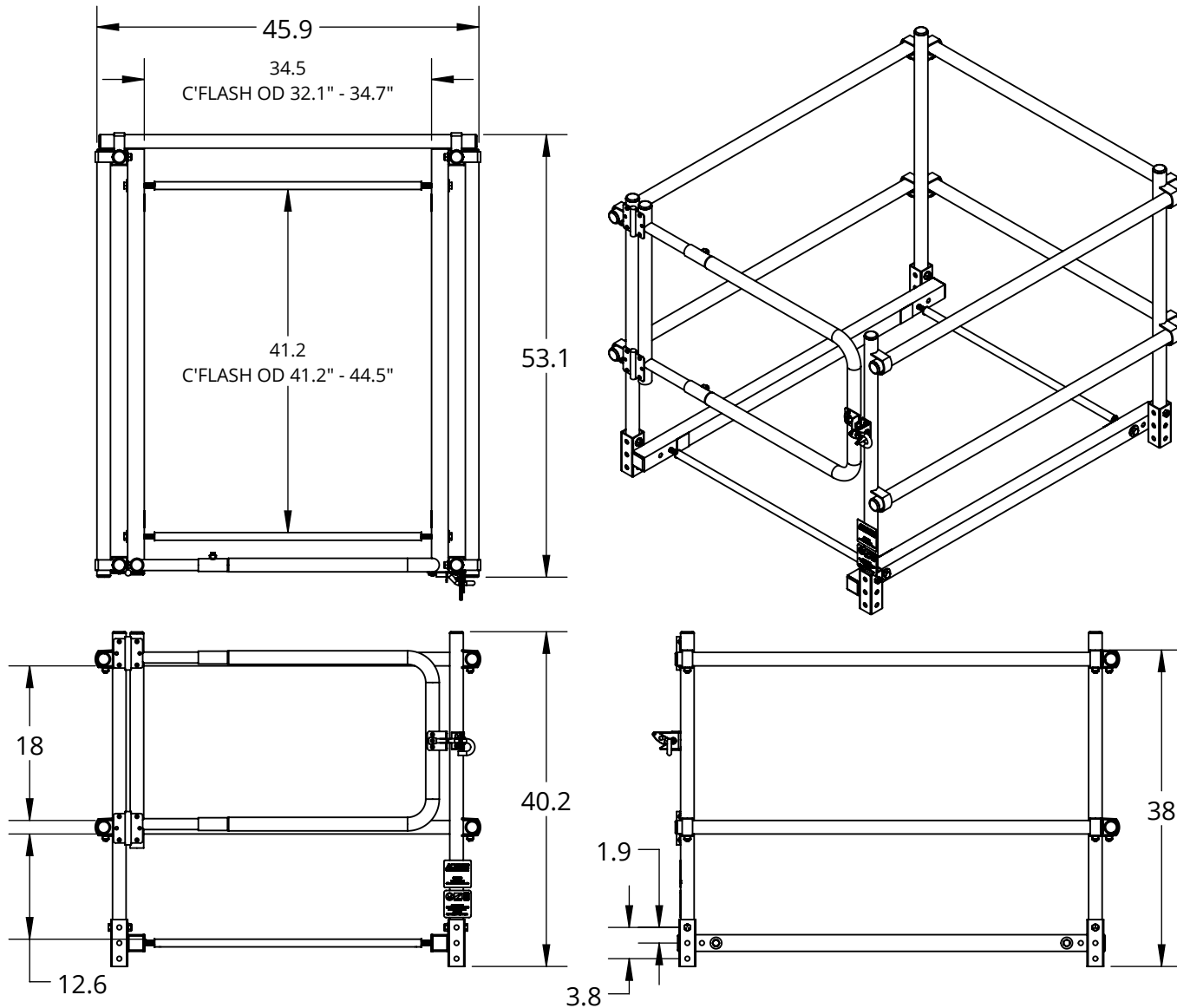

Specifications:

Material: 1-5/8" x .065" (16 gauge) galvanized steel tubing

Bracket Material: 2x2x.048" (18 gauge) square galvanized steel tubing

Finish: Yellow powder coat

Hinges: Steel, adjustable spring hinges

Latch: Steel, black powder coat pin hooks around gravity latch catch

Hardware: Black Plastic Tubing caps and zinc plated steel hardware

Size: Fits 37" x 30"(WxL) Roof Hatch, where L is hinged side. Gate exits on the Length

Performance: 200LBS with max 3" deflection per OSHA 1910.29, ANSI 1264.4

50 PLF (pounds per linear foot) per 2024 IBC 1607.9 (ASCE 7)

Notes:

The compression series can be mounted under the counterflashing.

Install the corner posts using one of the three vertical bolt holes so the top rail is 42" above the walking surface, as required by OSHA 1910.29(b)(1) and 2024 IBC 1015.3.

MODEL #: RSHWC-7LY



800-554-6077

sales@activarcpg.com

www.activarcpg.com

CANADA ONLY: 604-433-4243 info@maxammetal.com maxammetal.com

Distributor:

Contractor:

Date:

Scale: 1:20

Pages: 1 OF 2

Project:

Approved By:

Architect:

Drawing #:

RSHWC-7LY-SUBMITTAL

ITEM NO.	PART NUMBER	DESCRIPTION	QTY.
1	42845	POST, 4 LOOP ASSEMBLY	2
2	42849	POST, 2 LOOP ASSEMBLY HINGE SIDE	1
3	42852	POST, 2 LOOP ASSEMBLY LATCH SIDE	1
4	42863	HINGE, SPRING LOADED, 3-1/2"	2
5	42864	LATCH PIN, BENT, RIGHT HAND REVERSE	1
6	42865	BRACKET, GATE LATCH	1
7	43270	GATE, HINGE SIDE ASSEMBLY, SIZE 30"-48"	1
8	42860	GATE, LATCH SIDE ASSEMBLY	1
9	42866	LATCH CATCH	1
10	RS-PSX51	RAILING, 51"	4
11	RS-PSX45	RAILING, 45"	2
12	RS-CMA-51A	SQUARE TUBE ASSEMBLY, 51", COMPRESSION	2
13	RS-CME-32A	TUBE, 32", COMPRESSION	2
14	1FNE-XHFH-0C13	FLANGE NUT, 1/2"-13	4
15	1FSSE-XHH-0C1302C-PT	BOLT, 1/2"-13 X 2-1/2", PARTIAL THRD	4
16	1FSE-XHH-0C1304	SCREW, 1/2-13 X 4, HEX HEAD	4
17	1WZ050	WASHER, 1/2"	4
18	12P200	2.00" PLASTIC SQUARE INSERT	4
19	42871	BLACK GRIP TAPE	4
20	11P162	1-5/8" PLASTIC ROUND INSERT	17
21	1FSS8-HZ-0C130D	SET SCREW, 1/2"-13	14
22	1246	SCREW ROUND HEAD TORX 1/4-20X3/4 STEEL	13
23	JLMXDR-DECAL	DECAL "JL / MAXAM / DUR-RED" FOR ALL	1
24	LA-1017	DECAL, ACPG PATENTED LABEL	1

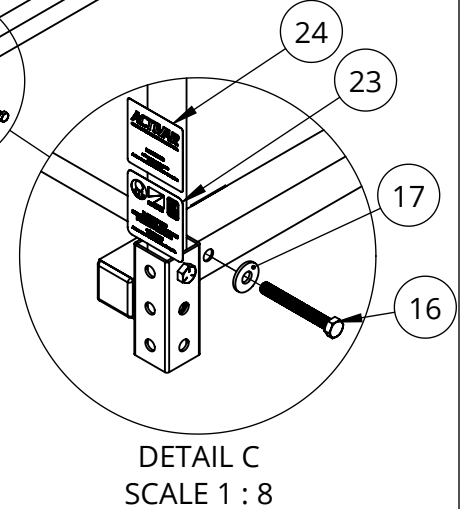
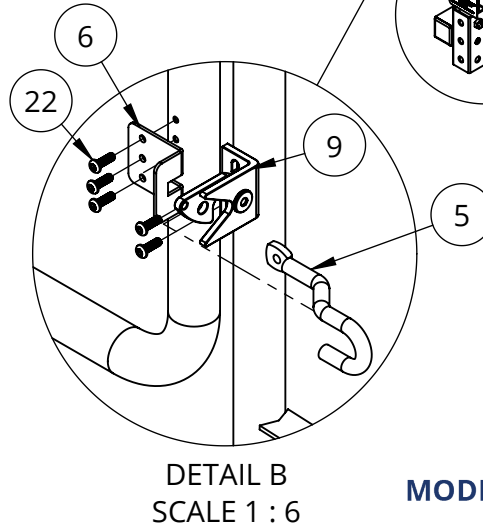
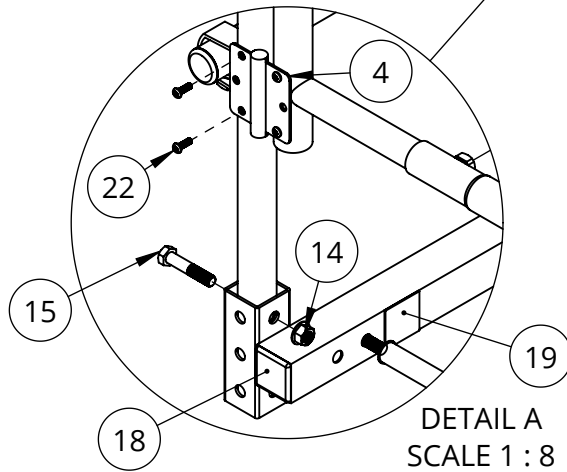
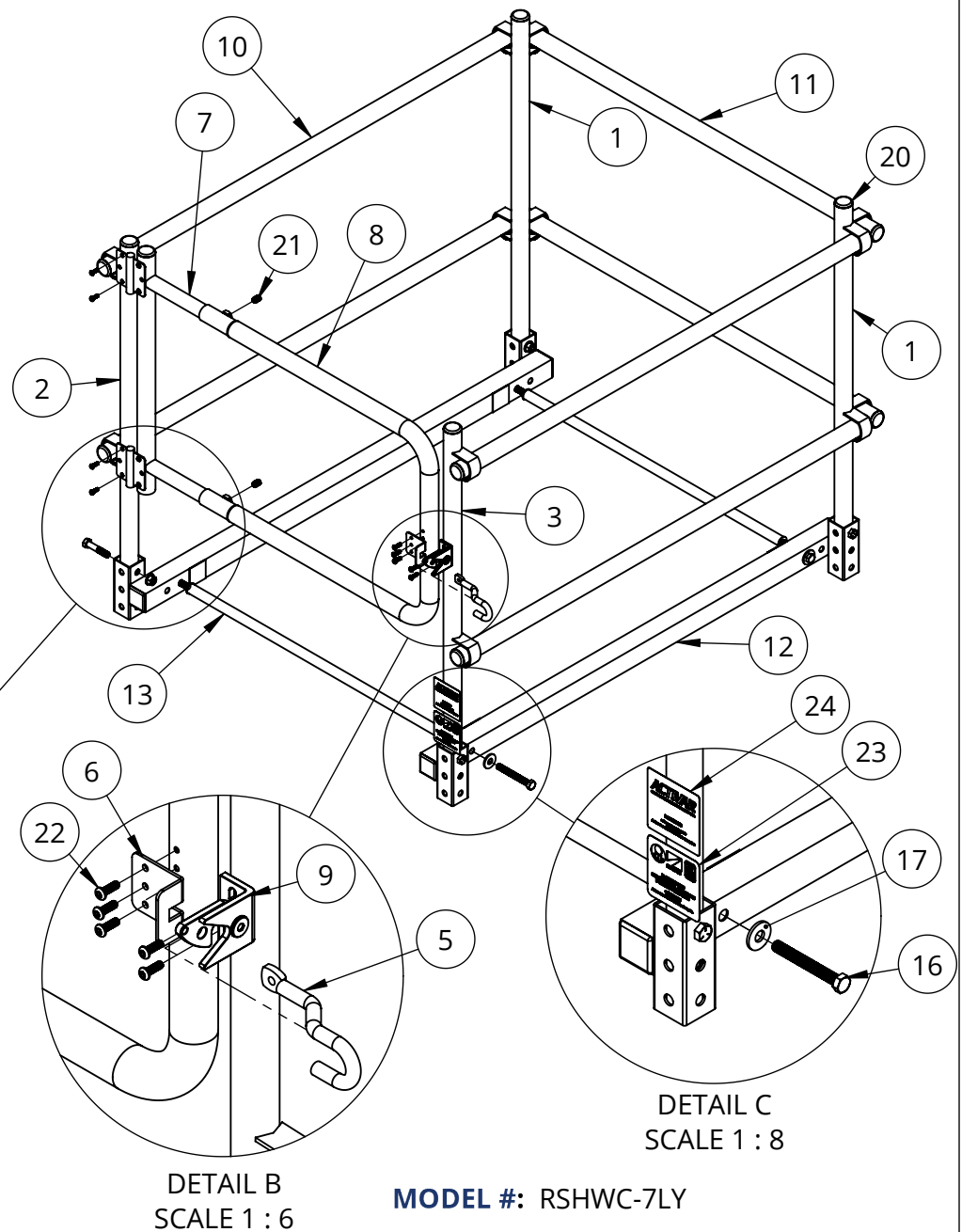

MODEL #: RSHWC-7LY



800-554-6077

sales@activarcpg.com

www.activarcpg.com

Distributor:

Contractor:

Date:

Scale: 1:16

Pages: 2 OF 2

Project:

Approved By:

Architect:

Drawing #:

RSHWC-7LY-SUBMITTAL

CANADA ONLY: 604-433-4243 info@maxammetal.com maxammetal.com