

## ROOF ACCESSORIES - SAFETY RAILING, BOLT-ON SERIES - RSHWB

The OSHA compliant bolt-on series safety railing is ideal for new roof hatch installations. It's designed to bolt on the curb counterflashing and does not penetrate the curb protecting the integrity of the roof membrane. In addition, the overall height is adjustable to ensure code compliance.

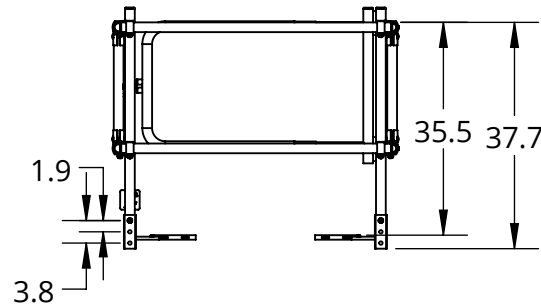
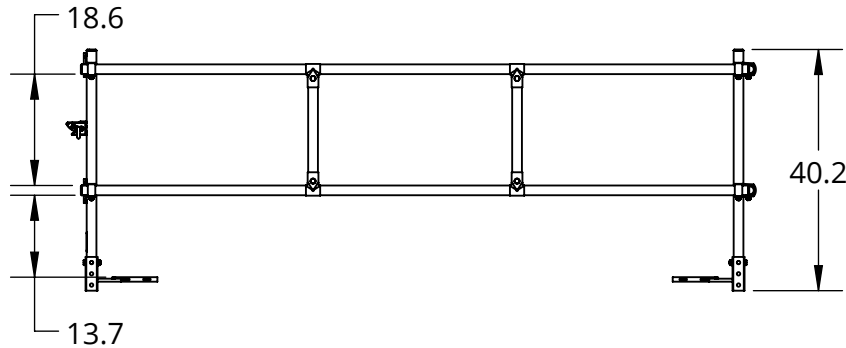
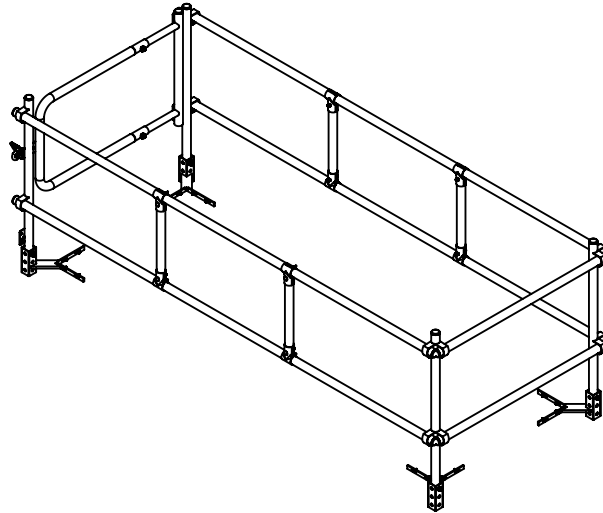
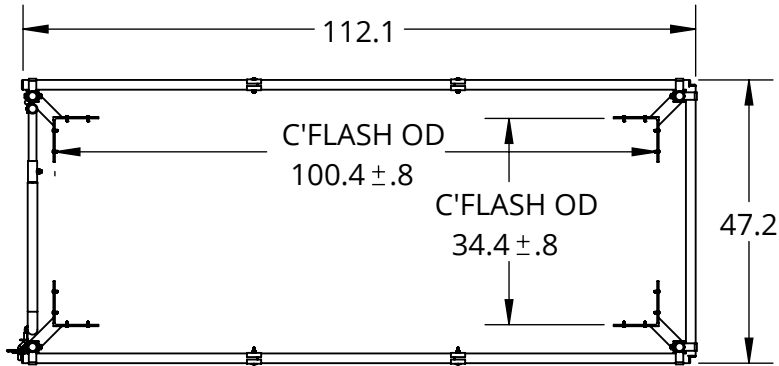

### Specifications:

**Material:** 1-5/8" x .065" (16 gauge) galvanized steel tubing

**Bracket Material:** 2x2x.120" square galvanized steel tubing, 1/4" and 1/2" plate CRS

**Finish:** Yellow powder coat

**Hinges:** Steel, adjustable spring hinges

**Latch:** Steel, black powder coat pin hooks around gravity latch catch

**Hardware:** Black Plastic Tubing caps and zinc plated steel hardware

**Size:** Fits 30" x 96"(WxL) Roof Hatch, where W is hinged side. Gate exits on the Width

**Performance:** 200LBS with max 3" deflection per OSHA 1910.29, ANSI 1264.4

50 PLF (pounds per linear foot) per 2024 IBC 1607.9 (ASCE 7)

### Notes:

Install the corner posts in one of the three vertical bolt holes so the top rail is 42" above the walking surface, as required by OSHA 1910.29(b)(1) and 2024 IBC 1015.3.

**MODEL #:** RSHWB-3WY



800-554-6077



sales@activarcpg.com



www.activarcpg.com

CANADA ONLY: 604-433-4243 info@maxammetal.com maxammetal.com

Distributor:

Contractor:

Date:

Scale: 1:32

Pages: 1 OF 2

Project:

Approved By:

Architect:

Drawing #:

RSHWB-3WY-SUBMITTAL

ITEM NO.	PART NUMBER	DESCRIPTION	QTY.
1	42845	POST, 4 LOOP ASSEMBLY	2
2	42849	POST, 2 LOOP ASSEMBLY HINGE SIDE	1
3	42852	POST, 2 LOOP ASSEMBLY LATCH SIDE	1
4	43227	CORNER MOUNT, ASSEMBLY, BOLT ON	4
5	42863	HINGE, SPRING LOADED, 3-1/2"	2
6	42860	GATE, LATCH SIDE ASSEMBLY	1
7	43270	GATE, HINGE SIDE ASSEMBLY, SIZE 30"-48"	1
8	42864	LATCH PIN, BENT, RIGHT HAND REVERSE	1
9	42865	BRACKET, GATE LATCH	1
10	42866	LATCH CATCH	1
11	RS-PSX45	RAILING, 45"	2
12	RS-PSX39	RAILING, 39"	8
13	RS-PSX40-S	RAILING, SWEDGE TUBE, 40"	4
14	43550	CLAMP ASSEMBLY WITH HOLE, END RAIL, 1-5/8"	8
15	RS-PSX17C	RAILING, 17-1/2"	4
16	1FSE-XHH-0B140D-DS	SCREW, 1/4 X 3/4, HEX, SELF DRILLING	8
17	1FSSE-XHH-0C1302C-PT	BOLT, 1/2"-13 X 2-1/2", PARTIAL THRD	4
18	1FNE-XHFH-0C13	FLANGE NUT, 1/2"-13	4
19	11P162	1-5/8" PLASTIC ROUND INSERT	17
20	1FSS8-HZ-0C130D	SET SCREW, 1/2"-13	14
21	1246	SCREW ROUND HEAD TORX 1/4-20X3/4 STEEL	29
22	JLMXDR-DECAL	DECAL "JL / MAXAM / DUR-RED" FOR ALL	1

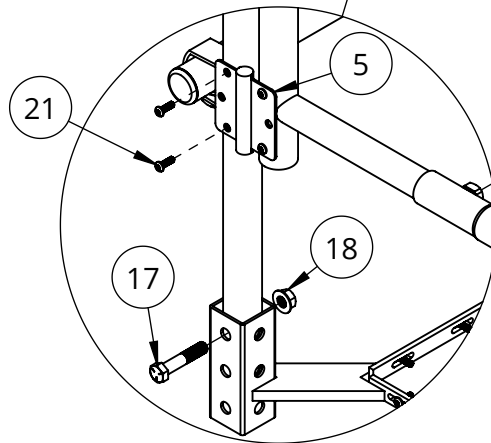
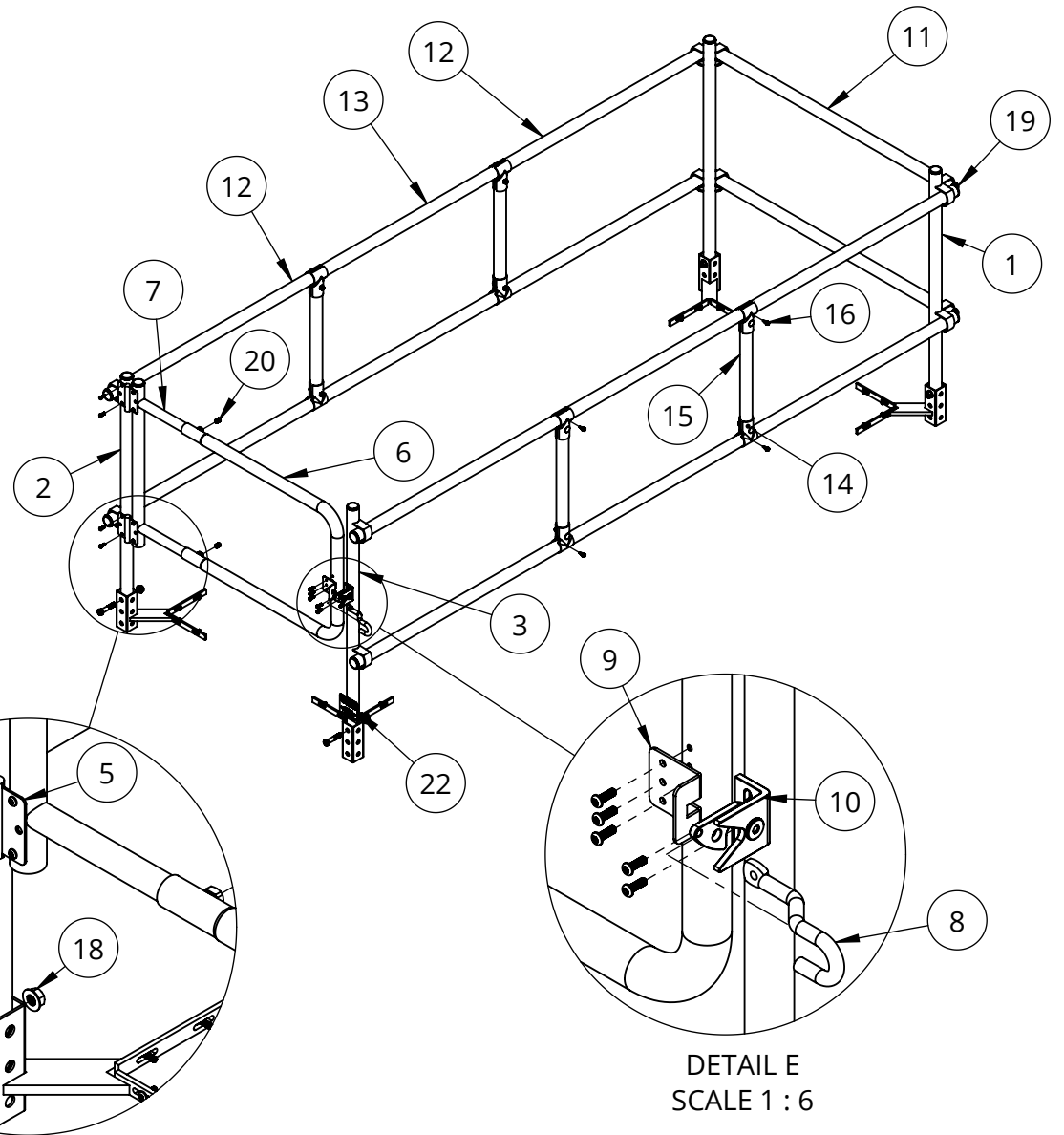

DETAIL D  
SCALE 1 : 8

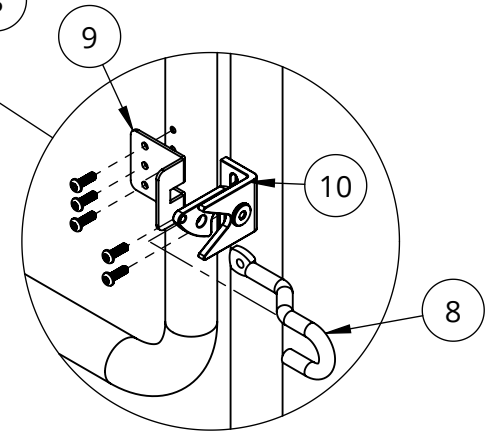

DETAIL E  
SCALE 1 : 6

**MODEL #:** RSHWB-3WY



800-554-6077



sales@activarcpg.com



www.activarcpg.com

CANADA ONLY: 604-433-4243 info@maxammetal.com maxammetal.com

Distributor:

Contractor:

Date:

Scale: 1:24

Pages: 2 OF 2

Project:

Approved By:

Architect:

Drawing #:

RSHWB-3WY-SUBMITTAL