

ROOF HATCH - Diamond Series™ - ROOF HATCH, DIAMOND SERIES 48 X 48 (RHA-5) | ALUM, MILL FINISH

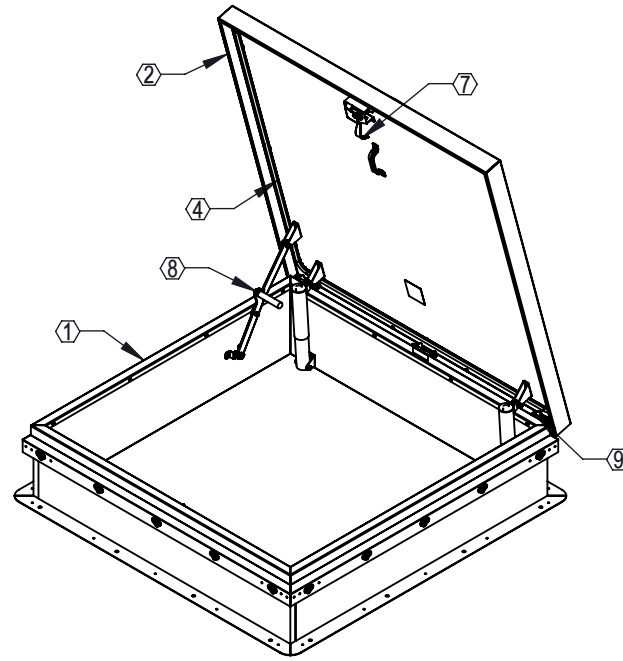
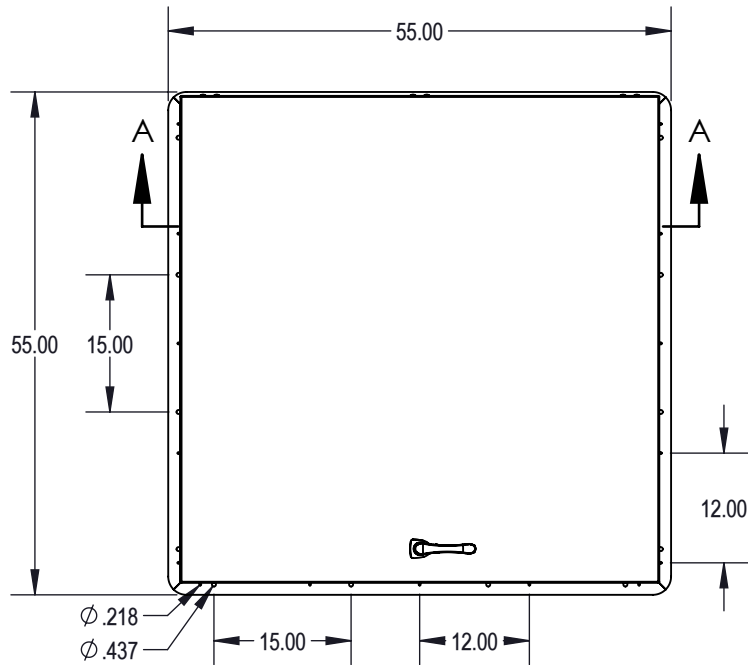

SPECIFICATIONS:

1. Curb: 11 gauge mill finish aluminum single wall curb and counterflashing with Diamond Grip.
2. Cover: 11 gauge aluminum formed, welded cover with 18 gauge liner, tested to support a live load of 40psf.
3. Finish: Mill Finish.
4. Gasket: Continuous, weatherproof EPDM sponge rubber adhesive-backed seal.
5. Insulation: 1" polyisocyanurate in curb and cover with thermal resistance R-6.
6. Spring: Counterbalanced compression springs contained in clear zinc-plated steel cylinders.
7. Latch: Clear zinc-plated steel slam latch with inside and outside handles and padlock hasps.
8. Hold Open Arm: Clear zinc-plated automatic locking hold open arm with red vinyl grip for one handed door operation.
9. Hinge: Heavy duty clear zinc-plated steel pintle hinge.

Notes:

For pitched roofs up to 7:12, mount hinge side parallel to slope.

Door opens 75°

Clear Opening: 37" X 42"

Weight: 112lbs

Diamond Series™ is a trademark of Activar Construction Products Group Inc.

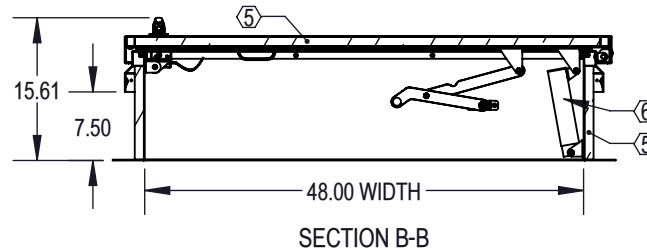
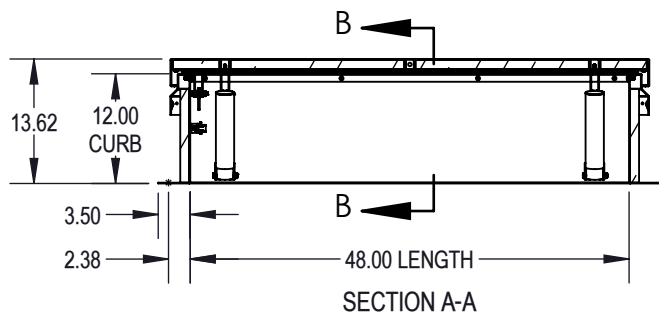

MODEL #: RHDA-5



800-554-6077
 sales@activarcpg.com
 www.activarcpg.com

9702 Newton Ave S. Bloomington, MN 55431 | Many Locations Nationwide

| | | |
|--------------|---------------|-----------------------------|
| Distributor: | | Project: |
| Contractor: | | Approved By: |
| Date: | Quantity: | Architect: |
| Scale: 1:21 | Pages: 1 OF 1 | Drawing #: RHDA-5-SUBMITTAL |