

Architectural Series, Fire Protection Cabinet, Ambassador - C1016W17FX2

FE FX2 CABINET, AMBASSADOR, 1-1/2" SQ TRIM, VERT DUO SAFTLOK, CLR TEMP, CRS TUB, CRS DR/TRM, ALL WHT, 10 TUB

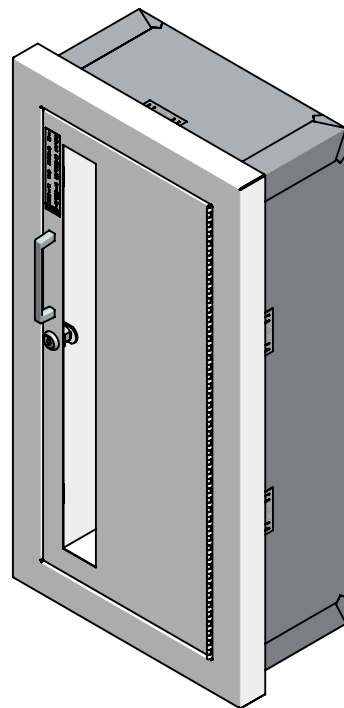
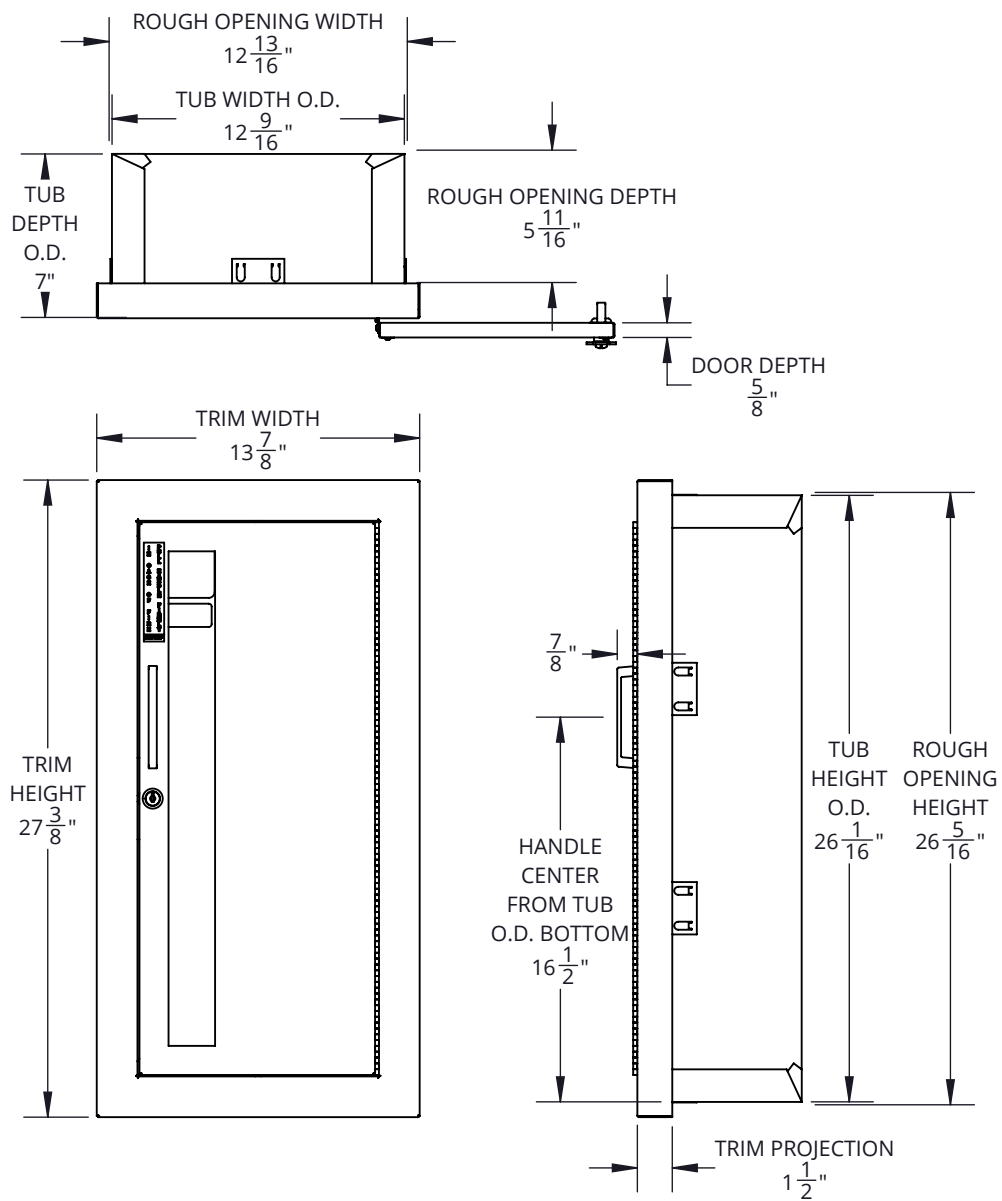

SPECIFICATIONS:

Tub Material: 24 gauge galvanized steel

Trim Material & Style: 20 gauge CRS, semi-recessed 1-1/2" square edge

Door Material & Style: 20 gauge CRS, vertical duo

Flange Material: 22 gauge galvanized steel

Glazing: 1/8" clear tempered glass (8-1/2" x 22-3/4")

Finish: Powder coat white door and trim, painted white tub

Hinge: Continuous hinge opens door 180 degrees, 20 gauge CRS powder coat white

Hardware: Zinc plated pull handle, Saf-T-Lok™, glass clips & screws

Rough Opening: 12-13/16" x 26-5/16" x 5-11/16"

Fire Rating: UL classified and labeled up to 2 hours in accordance with UL 1479 (ASTM-E814) and CAN/USC-S115.

Insulation: Wool insulation

ADA Compliant: Cabinet meets 4" maximum protrusion, locate handle maximum 48" above floor

Compatible Extinguisher: Cosmic 2.5lb. - 10lb., Galaxy 2.5lb - 10lb., Mercury 2.5lb. - 5lb., Sentinel 5lb.

MODEL # BREAKDOWN:

C — Product Line: Fire protection, cabinet

10 — Tub Size: 10-1/2" x 24" x 6"

1 — Trim and Door Material: CRS, powder coat finish

6 — Trim Style: Semi-recessed 1-1/2" square edge

W — Door Style: Vertical duo, pull handle, Saf-T-Lok™

17 — Door Glazing: 1/8" clear tempered glass

FX2 — Fire Rated

— Color: All white

REPLACEMENT PARTS:

Tub: TUB-10-6FX2

Trim: T-1016

Door: D-101W

Glazing: G10F17

Hardware Pack: HPPFUS, SL, LC

MODEL #: C1016W17FX2



800-554-6077
 sales@activarcpg.com
 www.activarcpg.com

9702 Newton Ave S. Bloomington, MN 55431 | Many Locations Nationwide

Distributor:		Project:
Contractor:		Approved By:
Date:	Quantity:	Architect:
Scale: 1:8.25	Pages: 1 OF 1	Drawing #: C1016W17FX2-SUBMITTAL