

Architectural Series, Fire Protection Cabinet, Ambassador - C1013F10
FE CABINET, AMBASSADOR, SURF MT, FULL VIEW, CLR ACR, ALL CRS, ALL WHT, 10 TUB

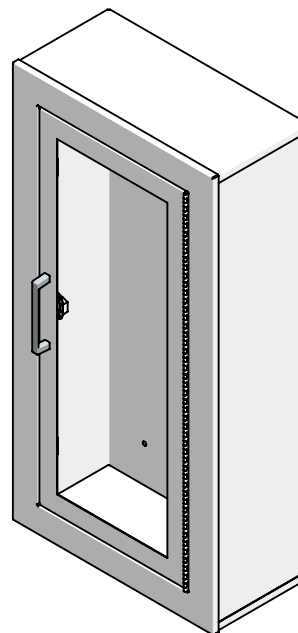
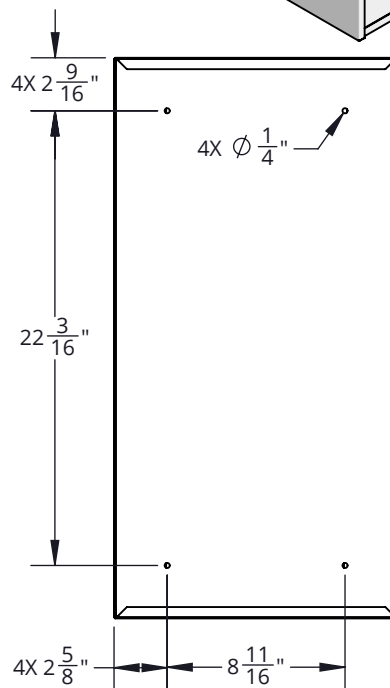
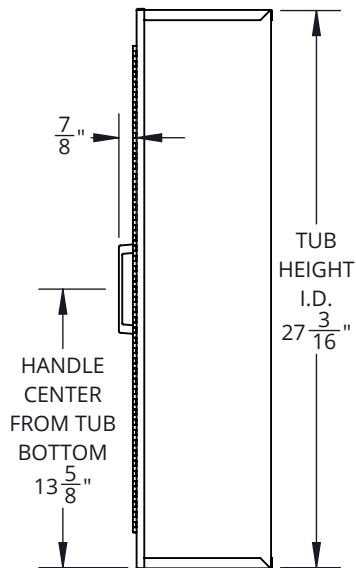
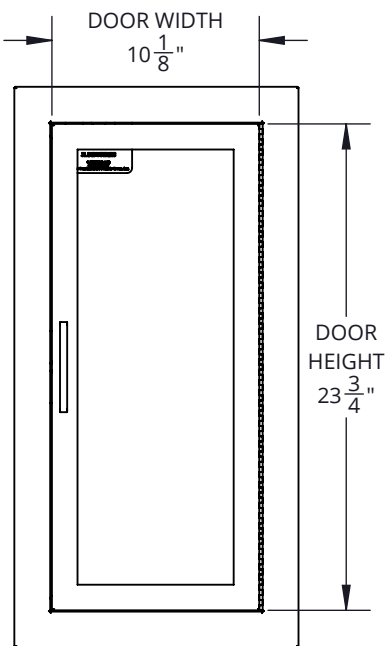
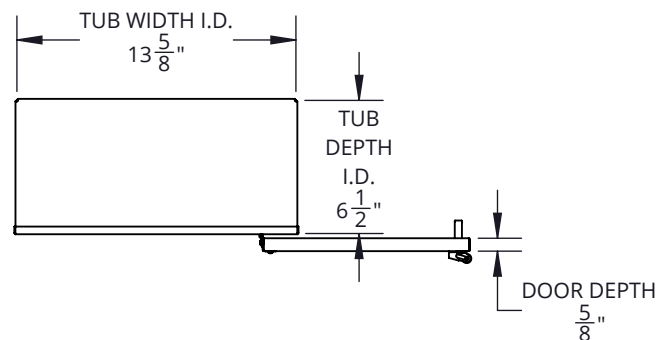

SPECIFICATIONS:

- Tub Material:** 22 gauge CRS
- Trim Material & Style:** 20 gauge CRS, surface mount square edge
- Door Material & Style:** 20 gauge CRS, full view
- Glazing:** 0.090" clear acrylic (8-1/2" x 22-3/4")
- Finish:** Powder coat white door, trim, and tub
- Hinge:** Continuous hinge opens door 180 degrees, 20 gauge CRS powder coat white
- Hardware:** Zinc plated pull handle, roller catch, glass clips & screws
- Fire Rating:** Not rated
- ADA Compliant:** Not compliant
- Compatible Extinguisher:** Cosmic 2.5lb. - 10lb., Galaxy 2.5lb - 10lb., Mercury 2.5lb. - 5lb., Sentinel 5lb.

MODEL # BREAKDOWN:

- C — Product Line: Fire protection, cabinet
- 10 — Tub Size: 13-11/16" x 27-3/16" x 6-1/2"
- 1 — Tub, Trim, and Door Material: CRS, powder coat finish
- 3 — Trim Style: Surface mount square edge
- F — Door Style: Full view, pull handle, roller catch
- 10 — Door Glazing: 0.090" clear acrylic
- Color: All white

REPLACEMENT PARTS:

- Tub: TUB-1013C
- Door: D-101F
- Glazing: G10F10
- Hardware Pack: HPFPUS

MODEL #: C1013F10



800-554-6077
 sales@activarcpg.com
 www.activarcpg.com

9702 Newton Ave S. Bloomington, MN 55431 | Many Locations Nationwide

Distributor:		Project:
Contractor:		Approved By:
Date:	Quantity:	Architect:
Scale: 1:8.375	Pages: 1 OF 1	Drawing #: C1013F10-SUBMITTAL